

CRF

- LOW NOISE LEVEL
- EXTERNAL ROTOR MOTOR
- BIRD CONTROL GRILLE
- FOLDING BODY FOR EASE OF INSPECTION

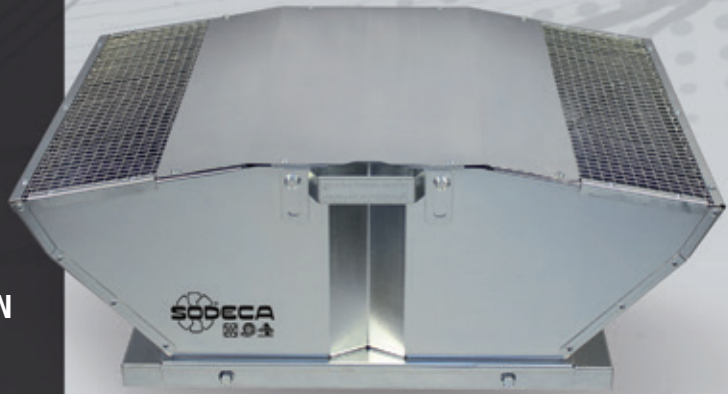

CRF/EW

- HIGH EFFICIENCY FAN
- E.C. BRUSHLESS INDUSTRIAL MOTOR
- BUILT-IN SPEED REGULATION
POWER METER
- LOW NOISE LEVEL
- EXTERNAL ROTOR MOTOR
- BIRD CONTROL GRILLE
- FOLDING BODY FOR EASE OF INSPECTION

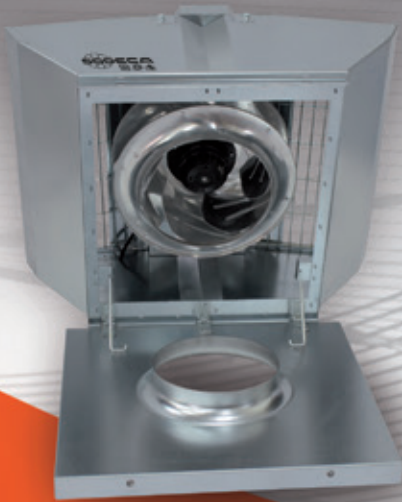
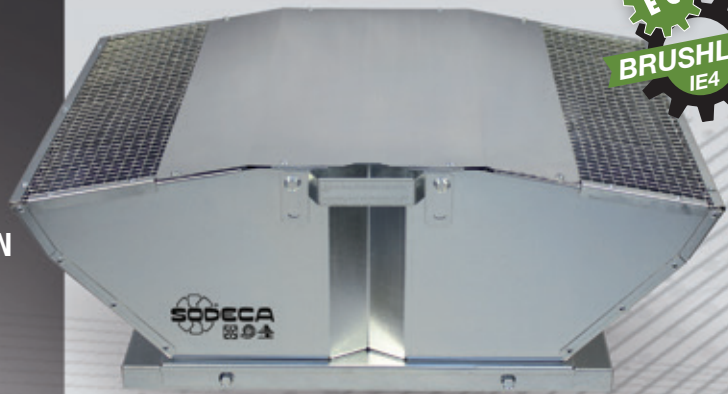

CRF CRF/EW

ROOF-MOUNTED
CENTRIFUGAL EXTRACTOR FANS

According ErP		CE	
FAN TYPE	MOTOR TYPE	ENERGY REQUIRED	ENERGY SAVE
CRF EW	EC+VSD	+++	45%
CRF	AC + VSD	++	35%
CRF	AC		0%



CRF

Roof-mounted centrifugal extractor fans, with low noise level



Roof-mounted centrifugal extractor fans with low noise level and external rotor motor.

Fan:

- Made of galvanised sheet steel.
- Turbine with reaction blades built of aluminium sheet metal except for models 225 and 250, which are made of galvanised sheet steel.
- Bird control grille.
- Folding body for ease of inspection and maintenance.

Motor:

- Class F motors, external rotor and IP54 protection.
- Single-phase 230V.-50/60Hz, except 450 and 500 230V.-50Hz models.
- Three-phase 400V.-50/60Hz, except 450 and 500 400V.-50Hz models.
- Maximum temperature of air to be carried: -25°C +50°C.

Finish:

- Corrosion-proof galvanised sheet steel.

On request:

- The variable speed drive (VSD) is supplied on request.

Order code

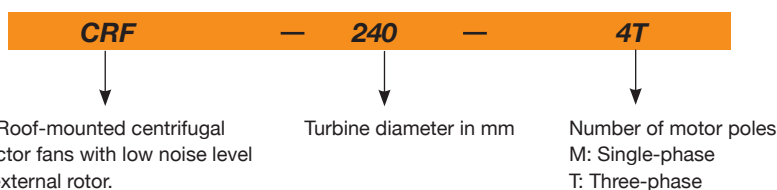

Technical characteristics

Model	Speed (r/min)	Maximum current admissible (A)		Installed electric power (kW)	Maximum flow rate (m³/h)	Sound pressure level dB(A) ⁽¹⁾		Weight (Kg)	VSD Recommended	ERP
		230V	400V			Aspiration	Discharge			
CRF-225-4M	1420	0.20		0.04	650	31	37	11	VSD1/M-0.5	2018
CRF-250-4M	1440	0.31		0.06	950	32	38	12	VSD1/M-0.5	2018
CRF-250-4T	1450		0.28	0.06	950	32	38	12	VSD3/A-RFT-1	2018
CRF-315-4M	1400	0.60		0.14	2000	39	45	17	VSD1/M-0.5	2018
CRF-315-4T	1430		0.35	0.14	2000	39	45	17	VSD3/A-RFT-1	2018
CRF-315-6M	940	0.38		0.08	1280	28	34	17	VSD1/M-0.5	2016
CRF-315-6T	900		0.20	0.07	1280	28	34	17	VSD3/A-RFT-1	2016
CRF-355-4M	1400	0.75		0.17	2500	43	48	24	VSD1/M-0.5	2018
CRF-355-4T	1400		0.45	0.18	2500	43	48	24	VSD3/A-RFT-1	2018
CRF-355-6M	930	0.46		0.10	1800	31	38	24	VSD1/M-0.5	2018
CRF-355-6T	950		0.32	0.10	1800	31	38	24	VSD3/A-RFT-1	2018
CRF-400-4M	1350	1.20		0.26	2810	46	52	28	VSD1/M-0.5	2018
CRF-400-4T	1380		0.60	0.27	2810	46	52	28	VSD3/A-RFT-1	2018
CRF-400-6M	940	0.72		0.14	2400	35	41	28	VSD1/M-0.5	2018
CRF-400-6T	900		0.40	0.15	2400	35	41	28	VSD3/A-RFT-1	2018
CRF-450-4M	1400	3.20		0.55	5400	53	59	42	VSD1/M-0.5	2018
CRF-450-4T	1340		1.00	0.55	5400	53	59	42	VSD3/A-RFT-1	2018
CRF-450-6M	930	1.30		0.26	3700	42	48	42	VSD1/M-0.5	2018
CRF-450-6T	920		1.00	0.30	3700	42	48	42	VSD3/A-RFT-1	2018
CRF-500-4T	1400		2.50	1.10	7600	57	62	51	VSD3/A-RFT-2	2018
CRF-500-6M	920	1.80		0.40	5200	45	52	51	VSD1/M-0.5	2018
CRF-500-6T	950		1.25	0.45	5200	45	52	51	VSD3/A-RFT-1	2018

(1) The noise level values are pressures in dB(A) measured at a distance of 6 metres and at 2/3 of the maximum flow rate (2/3 Qmax).

Acoustic characteristics

Noise power spectrum Lw(A) in dB(A) per Hz frequency band.

Values taken during aspiration with 2/3 maximum flow rate (2/3Qmax)

Model	63	125	250	500	1000	2000	4000	8000
225	29	35	46	49	50	46	44	38
250	30	36	47	50	51	47	45	39
315-4	40	49	54	54	58	57	50	44
315-6	29	38	43	43	47	46	39	33
355-4	44	53	58	58	62	61	54	48
355-6	32	41	46	46	50	49	42	36
400-4	48	54	60	60	63	66	57	51
400-6	37	43	49	49	52	55	46	40
450-4	55	61	67	67	70	73	64	58
450-6	44	50	56	56	59	62	53	47
500-4	60	67	72	72	76	75	68	63
500-6	48	55	60	60	64	63	56	51

Values taken during discharge with 2/3 maximum flow rate (2/3Qmax)

Model	63	125	250	500	1000	2000	4000	8000
225	33	38	52	54	55	55	50	45
250	34	39	53	55	56	56	51	46
315-4	39	48	58	62	65	62	55	49
315-6	28	37	47	51	54	51	44	38
355-4	42	51	61	65	68	65	58	52
355-6	32	41	51	55	58	55	48	42
400-4	47	59	67	69	70	70	62	54
400-6	36	48	56	58	59	59	51	43
450-4	54	66	74	76	77	77	69	61
450-6	43	55	63	65	66	66	58	50
500-4	58	70	78	80	81	78	71	63
500-6	48	60	68	70	71	68	61	53

To obtain the Lwa noise power spectra in dB(A) in aspiration at maximum flow rate (Qmax), add the values set out in the following chart to the LpA sound pressure level given in the characteristic curves:

Frequency band (Hz)								
63	125	250	500	1000	2000	4000	8000	
2	9	15	15	18	18	11	5	

Dimensions mm

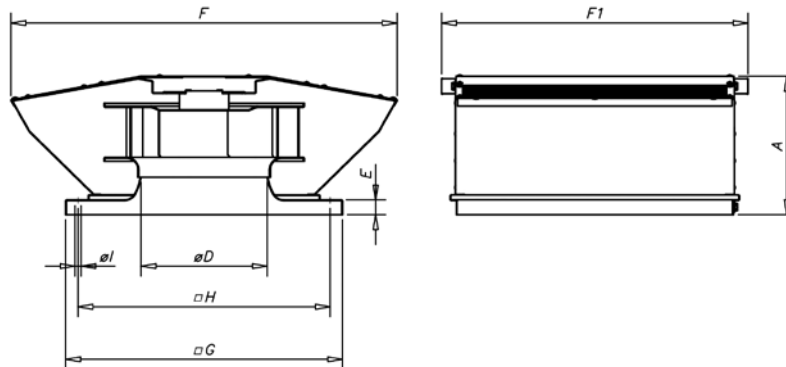

Model	A	ØD*	E	F	F1	G	H	øl
CRF-225	185	200	30	475	420	355	305	12
CRF-250	185	250	30	515	460	400	350	12
CRF-315	265	250	30	690	510	450	400	12
CRF-355	280	355	30	780	620	560	510	12
CRF-400	280	355	30	780	620	560	510	12
CRF-450	400	500	30	1110	775	710	660	12
CRF-500	400	500	30	1110	775	710	660	12

(*) Recommended pipe nominal diameter

Characteristic curves

Q= Flow rate in m³/h, m³/s and cfm.

Pe= Static pressure in mmH²O, Pa and inwg.

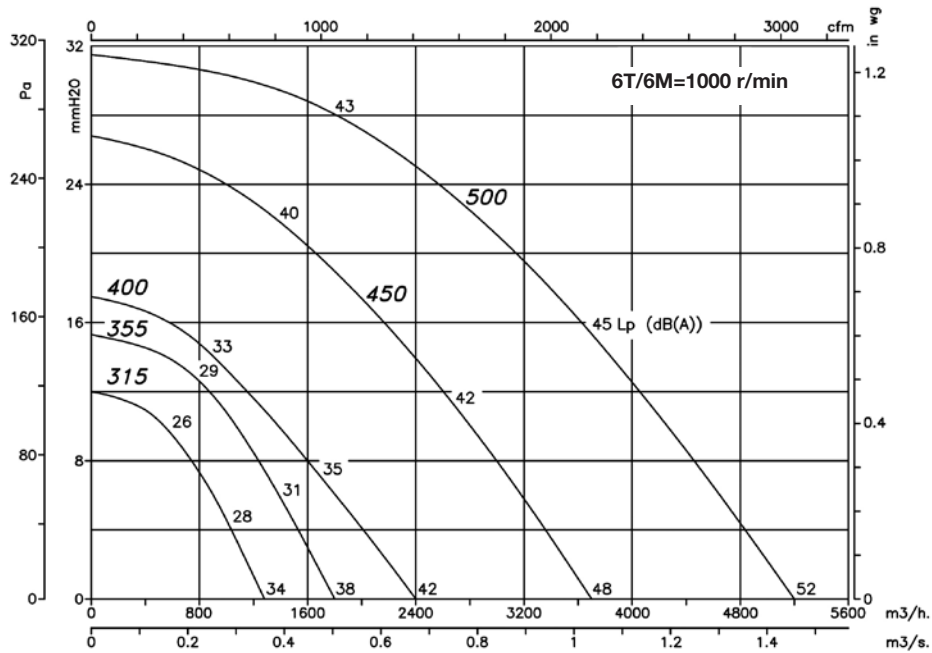
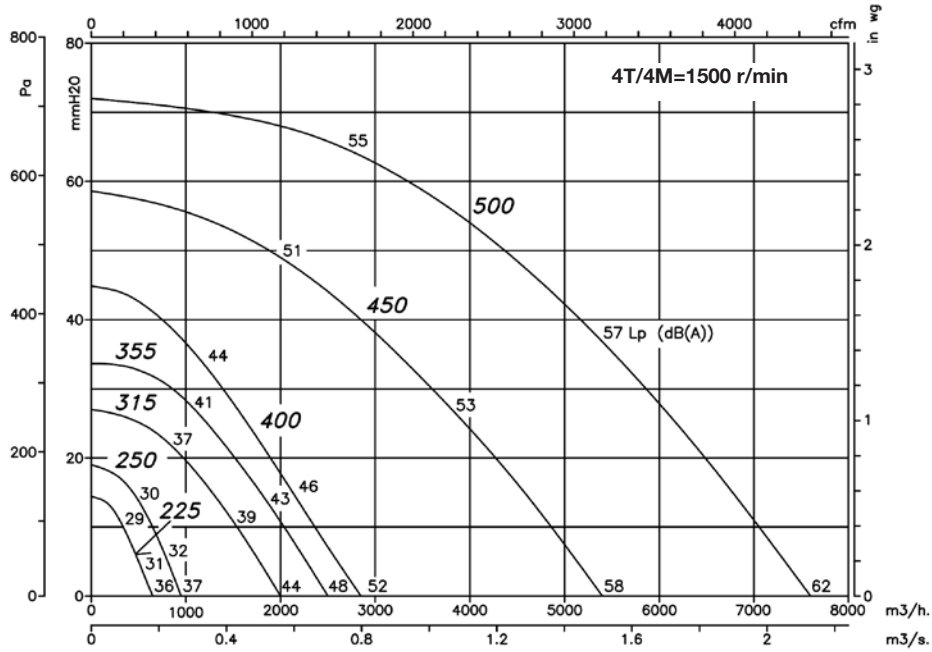

The Lp noise levels (dB(A)) indicated in the curves are pressures measured in a free field during aspiration, at 6 metres.

Accessories



CRF/EW



E.C. BRUSHLESS MOTOR WITH BUILT-IN VSD



Roof-mounted centrifugal extractor fans with low noise level, fitted with external E.C. brushless rotor motor

Roof-mounted centrifugal extractor fans with low noise level and external rotor motor, fitted with an E.C. Brushless industrial motor and a built-in speed regulating power meter.

Fan:

- Made of galvanised sheet steel.
- Turbine with reaction blades made of plastic material.
- Bird control grille.
- Folding body for ease of inspection and maintenance.

Motor:

- High efficiency EC external rotor motors regulated by 0-10V signal. IP54 protection.
- Single-phase 230V-50/60Hz and three-phase 400V-50/60Hz.
- Maximum temperature of air to be carried: -25°C +50°C.

Finish:

- Corrosion-proof galvanised sheet steel.

Order code

CRF/EW — 315 — M/L

CRF/EW: Roof-mounted centrifugal extractor fans with low noise level and EC external rotor motor.

Turbine diameter in mm

M: Single-phase
T: Three-phase

L: Low flow rate
M: Medium flow rate
H: High flow rate

Technical characteristics

Model	Maximum speed (r/min)	Maximum current admissible (A)		Installed electric power (kW)	Maximum flow rate (m³/h)	NPS at maximum speed (dBA) ⁽¹⁾		Approx. weight (Kg)	ERP
		230V	400V			Aspiration	Discharge		
CRF/EW-190-M	3200	0.75		0.083	695	42	45	10	2018
CRF/EW-250-M	2510	1.40		0.170	1305	44	47	12	2018
CRF/EW-315-M/L	1524	1.20		0.150	2170	35	38	16	2018
CRF/EW-315-M/H	2360	2.20		0.500	3365	49	52	18	2018
CRF/EW-400-M/L	1170	1.10		0.250	4020	39	42	26	2018
CRF/EW-400-M/M	1500	2.20		0.500	5285	45	48	27	2018
CRF/EW-400-M/H	1700	3.30		0.750	5830	49	52	28	2018
CRF/EW-400-T	2060		2.10	1.320	6330	51	58	29	2018
CRF/EW-500-M	1100	3.30		0.750	7950	43	49	48	2018
CRF/EW-500-T/L	1350		2.10	1.320	9560	48	54	50	2018
CRF/EW-500-T/H	1700		4.00	2.650	10625	53	60	59	2018

(1) The noise level values are pressures in dB(A) measured at a distance of 6 metres and at 2/3 of the maximum flow rate (2/3 Qmax).

Acoustic characteristics

Noise power spectrum Lw(A) in dB(A) per Hz frequency band.

Values taken during aspiration with 2/3 maximum flow rate (2/3Qmax)

Model	63	125	250	500	1000	2000	4000	8000
190-M	28	45	51	58	60	61	57	52
250-M	34	49	55	60	62	61	59	50
315-M/L	29	51	48	53	53	51	47	40
315-M/H	46	61	63	66	65	66	61	55
400-M/L	35	55	52	57	55	53	51	53
400-M/M	46	60	57	63	61	59	54	57
400-M/H	39	63	62	68	65	63	58	60
400-T	40	53	65	71	68	68	63	63
500-M	41	55	56	60	62	61	57	50
500-T/L	45	57	60	65	65	65	62	56
500-T/H	50	63	66	70	71	71	68	62
560-T/L	50	67	71	73	72	69	66	66
560-T/H	54	71	75	76	76	72	70	69
630-T/L	57	68	73	71	74	71	67	61
630-T/H	50	70	76	77	83	82	78	75

Values taken during discharge with 2/3 maximum flow rate (2/3Qmax)

Model	63	125	250	500	1000	2000	4000	8000
190-M	31	48	54	61	63	64	60	55
250-M	37	52	58	63	65	64	62	53
315-M/L	32	54	51	56	56	54	50	43
315-M/H	49	64	66	69	68	69	64	58
400-M/L	38	58	55	60	58	56	54	56
400-M/M	49	63	60	66	64	62	57	60
400-M/H	42	66	65	71	68	66	61	63
400-T	45	56	68	73	78	76	70	66
500-M	43	56	59	67	69	65	59	53
500-T/L	46	59	63	71	75	69	65	59
500-T/H	52	65	69	77	81	75	71	65
560-T/L	53	66	70	75	80	73	69	65
560-T/H	57	70	73	79	83	77	72	68
630-T/L	60	71	75	80	81	75	70	64
630-T/H	57	80	88	86	90	87	82	77

Dimensions mm

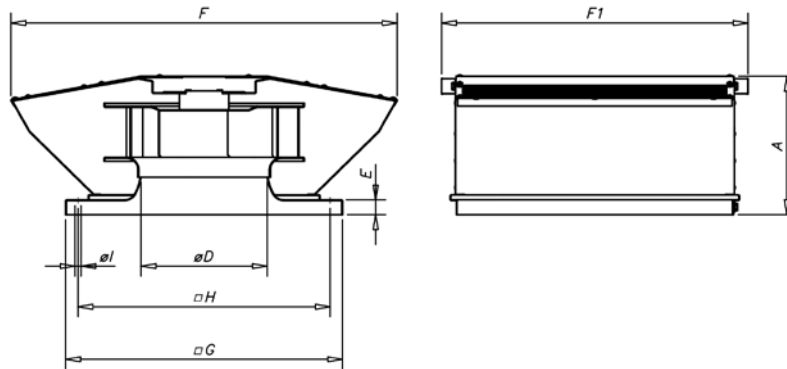

Model	A	ØD*	E	F	F1	G	H	øI
CRF/EW-190	185	200	30	475	420	355	305	12
CRF/EW-250	185	250	30	515	460	400	350	12
CRF/EW-315	265	250	30	690	510	450	400	12
CRF/EW-400	280	355	30	780	620	560	510	12
CRF/EW-500	400	500	30	1110	775	710	660	12

(*) Recommended pipe nominal diameter

Characteristic curves and ErP data

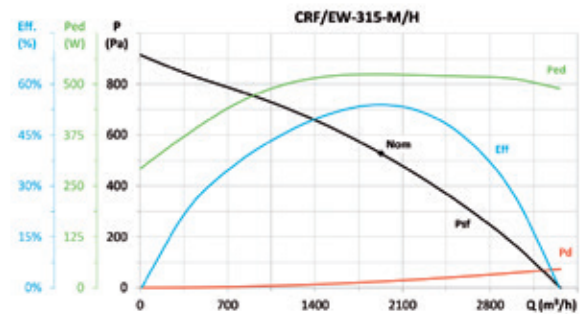
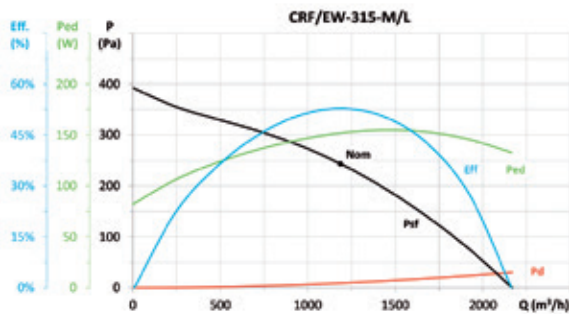
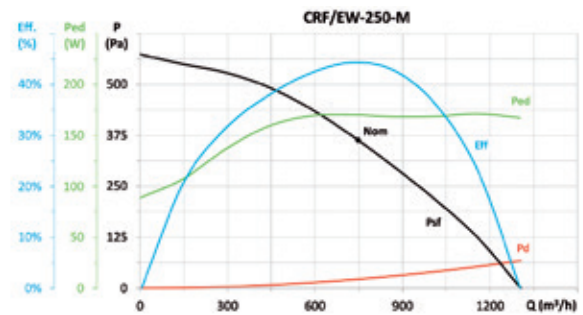
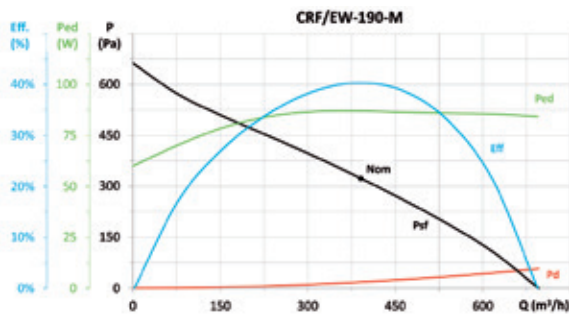

Characteristic curves and ErP data

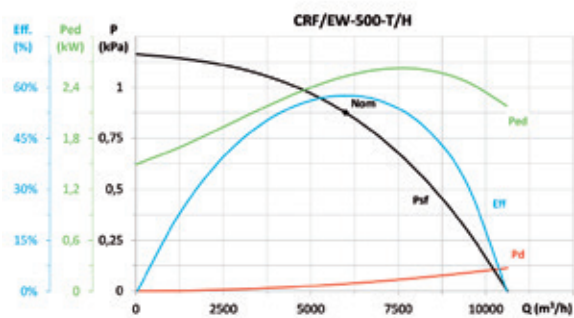
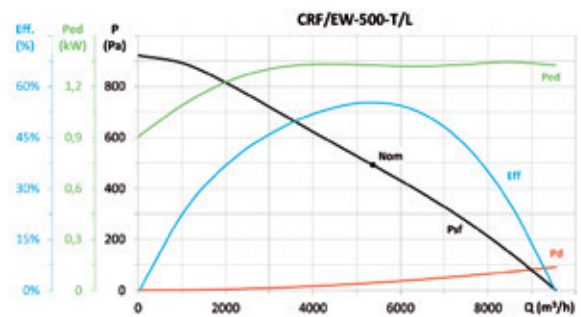
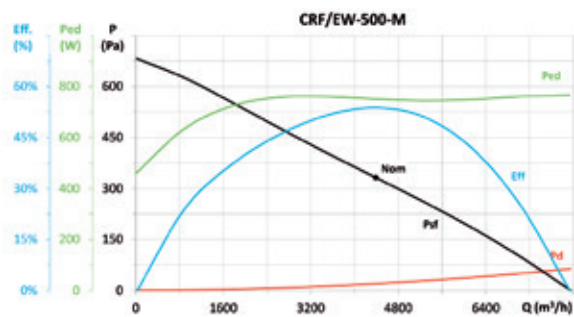
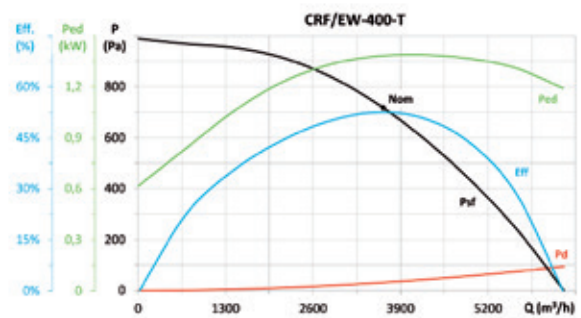
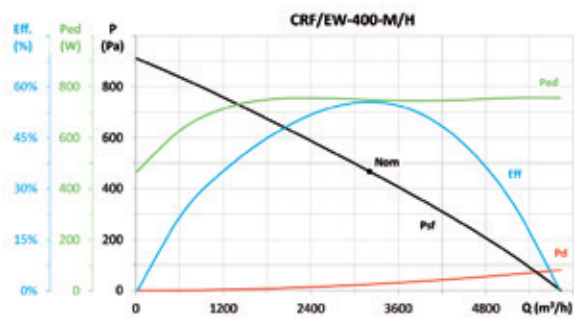
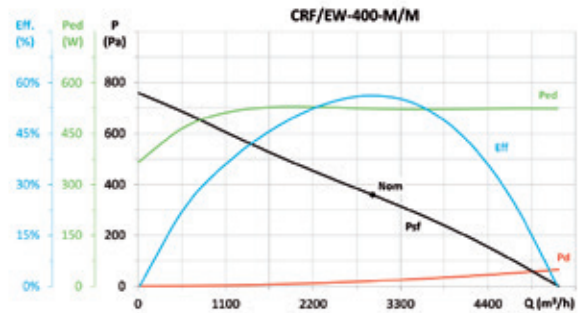
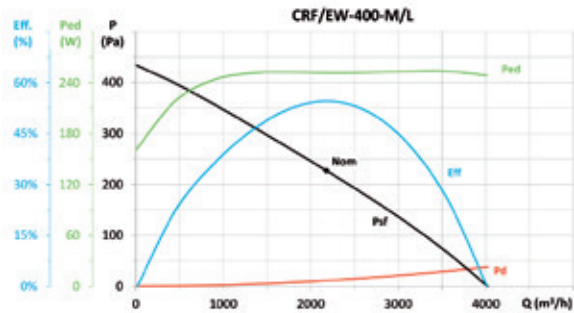

Accessories



INT

PA

MS

PT

SI

EFFICIENT WORK FANS



SOLution DEvelopment CAPacity

Fast and flexible industrial fan solutions and tailored fans
Extensive experience in smoke control systems and ATEX applications
Wide range of certified products for specific markets

AXIAL FANS AND
ROOF-MOUNTED EXTRACTOR
FANS



CENTRIFUGAL
FANS AND IN-LINE EXTRACTOR
FANS



SMOKE
EXTRACTOR
FANS



HEAVY DUTY FANS
AND EXTRACTOR FANS FOR
ATEX AND EXPLOSIVE
ATMOSPHERES



HEAT RECOVERY UNITS, AIR
FILTERING
AND TREATMENT UNITS



AIR CURTAINS FOR
COMMERCIAL AND INDUSTRIAL
APPLICATIONS



PRESSURISATION
SYSTEMS FOR
HOMES



ASK US
FOR INFORMATION
www.sodeca.com



SODECA Group



HEADQUARTER
Sodeca S.L.U.
Ctra. de Berga, km 0,7
E-08580 SANT QUIRZE DE
BESORA
Barcelona, SPAIN
Tel. +34 93 852 91 11
Fax +34 93 852 90 42
General sales:
comercial@sodeca.com
Export sales:
ventilation@sodeca.com

CHILE
Sodeca Ventiladores Ltda
Sr. Frederic Cousquer
Santa Bernardita 12.005
(Esquina con Puerta Sur)
Bodegas 24 a 26
03380 San Bernardo,
Santiago, CHILE
Tel. +56 22 840 5582
ventas.chile@sodeca.com

COLOMBIA
Sodeca Ventiladores S.A.S
Sra. Luisa Stella Prieto
Avenida 1 de Mayo
N°72N - 45/47 Sur
Bogotá, COLOMBIA
Tel. +57 1 293 7272
ventascolombia@sodeca.co

PORTUGAL
Sodeca Portugal Lda
PORTO
Rua Veloso Salgado 1120/1138
4450-801 Leça de Palmeira,
Tel. +351 229 991 100
Fax. +351 229 991 119
geral@sodeca.pt

FINLAND
Sodeca Finland Oy
Mr. Kai Yli-Sipilä
Metsälinnankatu 30, PL2,
FI-32700 Huittinen,
FINLAND
Tel. + 358 400 320 125
orders.finland@sodeca.com

PORTUGAL
Sodeca Portugal Lda
LISBOA
Parque Empresarial da Granja
Pavilhão 8
2625-607 Vialonga,
Tel. +351 219 748 491
Fax. +351 219 748 493
geral@sodeca.pt

RUSSIA
Sodeca, L.L.C.
Mr. Stanislav Alifanov
Myasisheva str, 1, room 603
Business Center "Chaika"
140180 Zhukovskiy,
Moscow, RUSSIA
Tel. +7 495 955 90 50
alifanov@sodeca.com

UNITED KINGDOM
Sodeca Fans UK Ltd
Mr. Mark Newcombe
Pacific House
Relay Point
Tamworth, B77 5PA
UNITED KINGDOM
Tel. +44 (0) 1827 264 435
Mob. +44 (0) 7488 517433
sales@sodeca.co.uk

ZONA CARIBE
Sodeca Cuba
Sr. Carlos Hernández
Residencial Miramar
Apto. N° 108
Ave. 7ma N° 1805 entre 18 y 20
Miramar Playa, Havana, CUBA
Tel. +537 20 43721
carlos@sodeca.co.cu